

Model 4045R

SCISSOR LIFTS

Performance

• Working Height	13.96 m
A. Stowed height	2.55 m
B. Platform Height - Lowered	1.4 m
C. Platform Railing Height	1.13 m
D. Stowed Height (Rails Folded)	1.92 m
E. Platform Size Inside (W x L)	1.05 m x 2.43 m
F. Deck Extension	0.91 m
G. Overall Width	1.14 m
H. Overall Length ²	2.71 m
I. Wheelbase	2.03 m
J. Ground Clearance (centre of machine)	12,6 cm
• Platform Capacity - Indoor	👤 / 350 kg
• Platform Capacity - Outdoor	👤 / 250 kg
• Capacity on Deck Extension	113 kg
• Lift/Lower Time (no load)	68/41 sec.
• Maximum Drive Height - Indoor	11.96 m
• Maximum Drive Height - Outdoor	8.74 m
• Machine weight ¹	3,175 kg
• Maximum Ground Bearing Pressure	9,00 kg/cm ²
• Drive Speed - Lowered	3.22 km/h
• Drive Speed - Elevated	0.8 km/h
• Gradeability	25%
• Turning Radius - Inside	0.0 m
• Turning Radius - Outside	2.54 m
• Tyres (Non-Marking Solid)	406 x 127
• Brakes	Hydraulic
• Drive (Nominal)	Hydraulic
• Batteries	4x 12V 150A/hr
• Charger (120/240V -50/60Hz)	24v @27Amp Automatic
• Pump Motor	4.5kW
• Hydraulic System	30L



¹ Certain options or country standards may increase weight and/or dimensions.
² includes ladder, excluding ladder 2.56 m

Dimensions

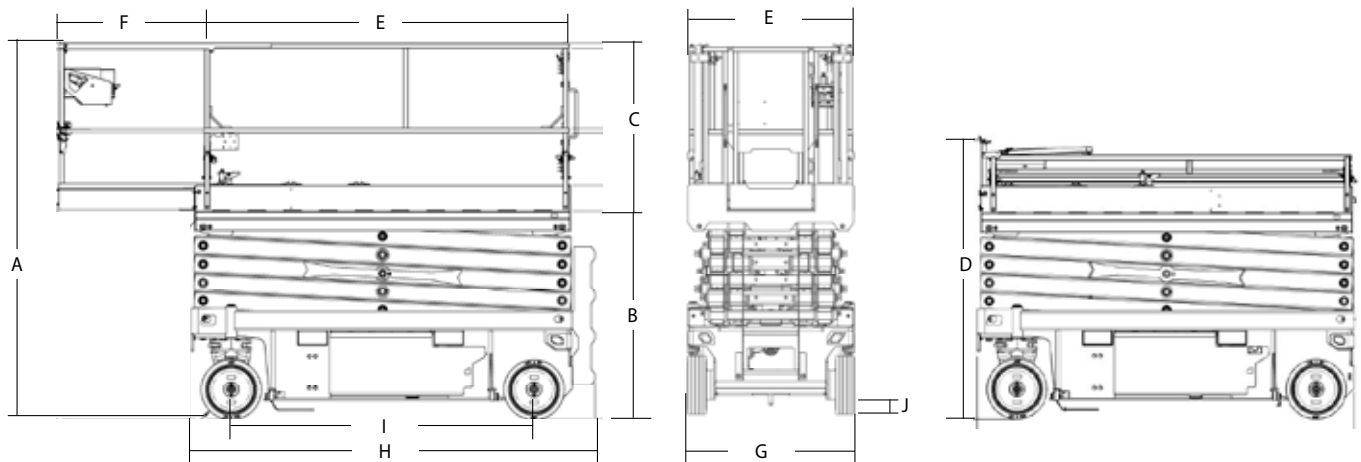

IMPORTANT

JLG is continually researching and developing products and reserves the right to make modifications without prior notice. All data in this document is indicative. Certain options or country standards will increase weight. Specifications may change to meet country standards or with the addition of optional equipment.



JLG EMEA BV

Polaris Avenue 63
 2132 JH Hoofddorp
 The Netherlands
 Phone: +31 (0)23 565 5665
www.jlg.com

Due to continuous product improvements, JLG Industries reserves the right to make specification and/or equipment changes without prior notification.

An Oshkosh Corporation Company